

Interface Relay Modules

- Increases the switching current capacity of low-voltage primary safety devices to 6 amps
- Serves as a relay for primary safety devices with OSSD solid-state or hard contact outputs and external device monitoring, such as the EZ-SCREEN®
- Uses two green LEDs to indicate the output status of internal relays K1 and K2
- Responds in 20 milliseconds maximum
- Mounts on DIN rail

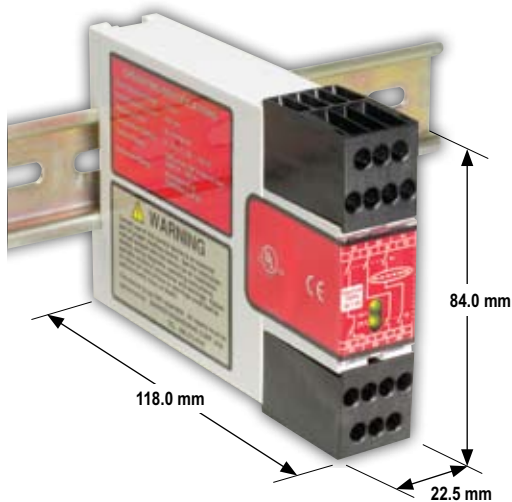

Interface Models



Interface Modules

Supply Voltage	Inputs	Safety Outputs	Aux. Outputs	Output Rating	Output Response Time	Models
24V dc	2 NC (dual)	3 NO	—	6 amps	20 ms	IM-T-9A
		2 NO	1 NC			IM-T-11A

NC = Normally Closed Relay, NO = Normally Open Relay

Interface Modules Specifications	
Input Voltage and Current	24V dc, +/-15% no polarity, 10% max. ripple; 50 mA per input channel Power consumption: approx. 2.4 W
Supply Protection Circuitry	Protected against transient voltages.
Overvoltage Category	Output relay contact voltage of 1V to 150V ac/dc: Category III Output relay contact voltage of 151V to 250V ac/dc: Category II (Category III, if appropriate overvoltage reduction is provided, as described in data sheet.)



Interface Modules Specifications (cont'd)

Pollution Degree	2																		
Output Configuration	<p>IM-T-9A: 3 normally open output channels IM-T-11A: 2 normally open output channels and 1 normally closed auxiliary output channel. Each normally open output channel is a series connection of contacts from two forced-guided (mechanically linked) relays, K1-K2. The normally closed contact 31-32 is a parallel connection of contacts from K1-K2. Contacts: AgNi, 5 µm gold-plated</p> <p>Low Current Rating: The 5 µm gold-plated contacts allow the switching of low current/low voltage. In these low-power applications, multiple contacts can also be switched in series (e.g., "dry switching"). To preserve the gold plating on the contacts, do not exceed the following max. values at any time:</p> <table style="width: 100%; border: none;"> <tr> <td style="padding-right: 20px;">Min. voltage: 1V ac/dc</td> <td>Max. voltage: 60V</td> </tr> <tr> <td>Min. current: 5 mA ac/dc</td> <td>Max. current: 300 mA</td> </tr> <tr> <td>Min. power: 5 mW (5 mVA)</td> <td>Max. power: 7 W (7 VA)</td> </tr> </table> <p>High Current Rating: If higher loads must be switched through one or more of the contacts, the minimum and maximum values of the contact(s) changes to:</p> <table style="width: 100%; border: none;"> <tr> <td style="padding-right: 20px;">Min. voltage: 15V ac/dc</td> <td>Max. voltage: 250V ac/dc, 6A resistive</td> </tr> <tr> <td>Min. current: 30 mA ac/dc</td> <td>Max. power: 150 W (1,500 VA)</td> </tr> <tr> <td>Min. power: 0.45 W (0.45 VA)</td> <td>IEC 60947-5-1: AC-15: 230V ac, 3A; DC-13: 24V dc, 4 A</td> </tr> </table> <p>Mechanical life: 20,000,000 operations Electrical life: 150,000 cycles @ 1500 VA; 1,000,000 cycles @ 450 VA; 2,000,000 cycles @ 250 VA; 5,000,000 VA @ 125 VA</p> <p>Feedback contact rating (Y1-Y2, Y3-Y4):</p> <table style="width: 100%; border: none;"> <tr> <td style="padding-right: 20px;">Min. voltage: 1V ac/dc</td> <td>Max. voltage: 60V</td> </tr> <tr> <td>Min. current: 5 mA ac/dc</td> <td>Max. current: 300 mA</td> </tr> <tr> <td>Min. power: 5 mW (5 mVA)</td> <td>Max. power: 7 W (7 VA)</td> </tr> </table> <p>NOTE: Transient suppression is recommended when switching inductive loads. Install suppressors across load. Never install suppressors across output contacts.</p>	Min. voltage: 1V ac/dc	Max. voltage: 60V	Min. current: 5 mA ac/dc	Max. current: 300 mA	Min. power: 5 mW (5 mVA)	Max. power: 7 W (7 VA)	Min. voltage: 15V ac/dc	Max. voltage: 250V ac/dc, 6A resistive	Min. current: 30 mA ac/dc	Max. power: 150 W (1,500 VA)	Min. power: 0.45 W (0.45 VA)	IEC 60947-5-1: AC-15: 230V ac, 3A; DC-13: 24V dc, 4 A	Min. voltage: 1V ac/dc	Max. voltage: 60V	Min. current: 5 mA ac/dc	Max. current: 300 mA	Min. power: 5 mW (5 mVA)	Max. power: 7 W (7 VA)
Min. voltage: 1V ac/dc	Max. voltage: 60V																		
Min. current: 5 mA ac/dc	Max. current: 300 mA																		
Min. power: 5 mW (5 mVA)	Max. power: 7 W (7 VA)																		
Min. voltage: 15V ac/dc	Max. voltage: 250V ac/dc, 6A resistive																		
Min. current: 30 mA ac/dc	Max. power: 150 W (1,500 VA)																		
Min. power: 0.45 W (0.45 VA)	IEC 60947-5-1: AC-15: 230V ac, 3A; DC-13: 24V dc, 4 A																		
Min. voltage: 1V ac/dc	Max. voltage: 60V																		
Min. current: 5 mA ac/dc	Max. current: 300 mA																		
Min. power: 5 mW (5 mVA)	Max. power: 7 W (7 VA)																		
Output Response Time	20 milliseconds max.																		
Status Indicators	2 green LED indicators: K1 energized K2 energized																		
Construction	Polycarbonate housing																		
Environmental Rating	Rated NEMA 1; IEC IP20																		
Mounting	Mounts to standard 35 mm DIN rail track. Interface Module must be installed inside an enclosure rated NEMA 3 (IP54), or better.																		
Vibration Resistance	10 to 55Hz @ 0.35 mm displacement per IEC 60068-2-6																		
Operating Conditions	Temperature: 0° to +50° C Relative humidity: 90% @ 50° C (non-condensing)																		
Design Standards	EN 60204-1, IEC 61810-1, EN 60255-1, EN 50205																		
Application Notes	There are no adjustments or user-serviceable parts.																		
Certifications																			
Wiring Diagrams	<p>2-Channel, 2 OSSDs, 2-Channel EDM: WD061 (p. 816) 2-Channel, 2 OSSDs, 1-Channel EDM: WD062 (p. 816) 2-Channel, 2 FSDs, 2-Channel EDM: WD063 (p. 817) 2-Channel, 2 OSSDs, 1-Channel EDM: WD063 (p. 817) 1-Channel, 1 Relay, 1 EDM: WD064 (p. 818)</p>																		

- Photoelectrics
- Sensors
- Fiber Optic
- Sensors
- Special Purpose
- Sensors
- Measurement &
- Inspection Sensors
- Vision
- Wireless
- Lighting &
- Indicators
- Safety
- Light Screens
- Safety
- Laser Scanners
- Fiber Optic
- Safety Systems
- Safety Controllers &**
- Modules**
- Safety Two-Hand
- Control Modules
- Safety Interlock
- Switches
- Emergency Stop &
- Stop Control

- SAFETY
- CONTROLLERS
- SAFETY**
- MODULES**
- E-STOP & GUARD
- UNIVERSAL
- SAFETY MAT
- MUTING
- SAFE SPEED
- EXTENSION
- INTERFACE

WD061

IM-T...A Interface Module



Page 548

- Models**
- IM-T-9A
 - IM-T-11A

IM-T...A Terminal Locations

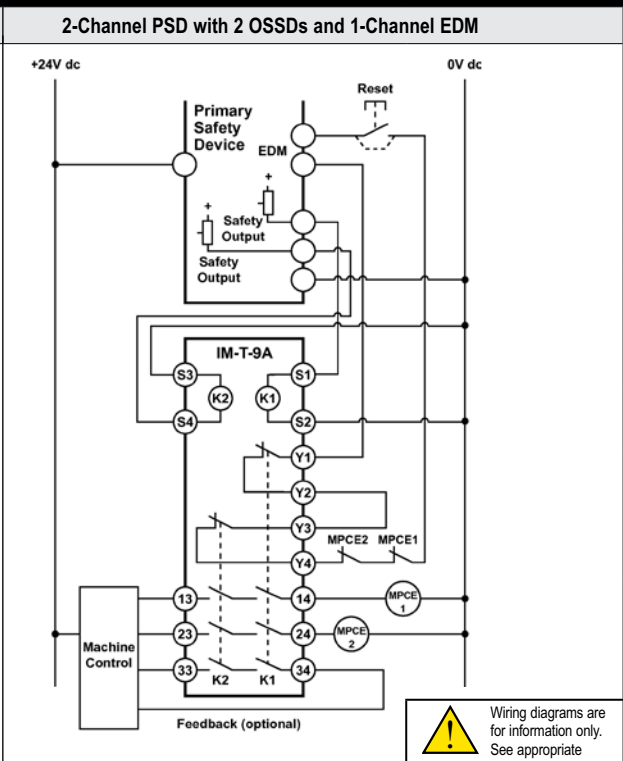
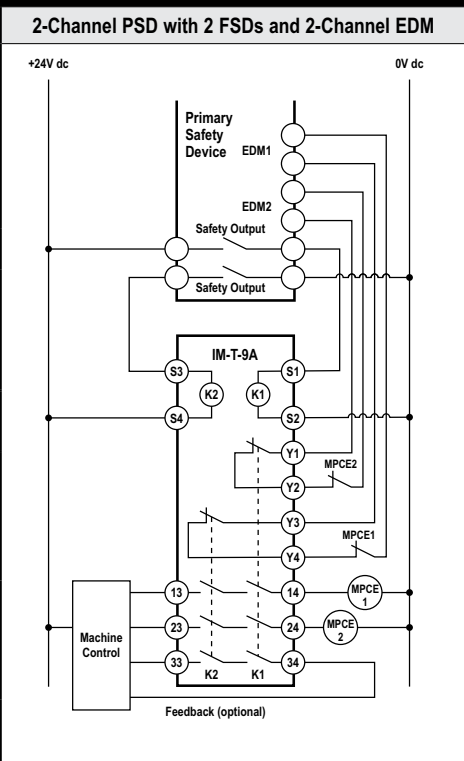
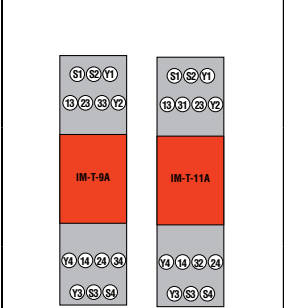

If arc suppressors are used, they **MUST** be installed across the coils of machine primary control elements (MPCE 1 and MPCE 2). See manual for specific warnings.

Wiring diagrams are for information only. See appropriate manuals for all specific warnings, cautions and information for use.

WD062

IM-T...A Interface Module



Page 548

- Models**
- IM-T-9A
 - IM-T-11A

IM-T...A Terminal Locations

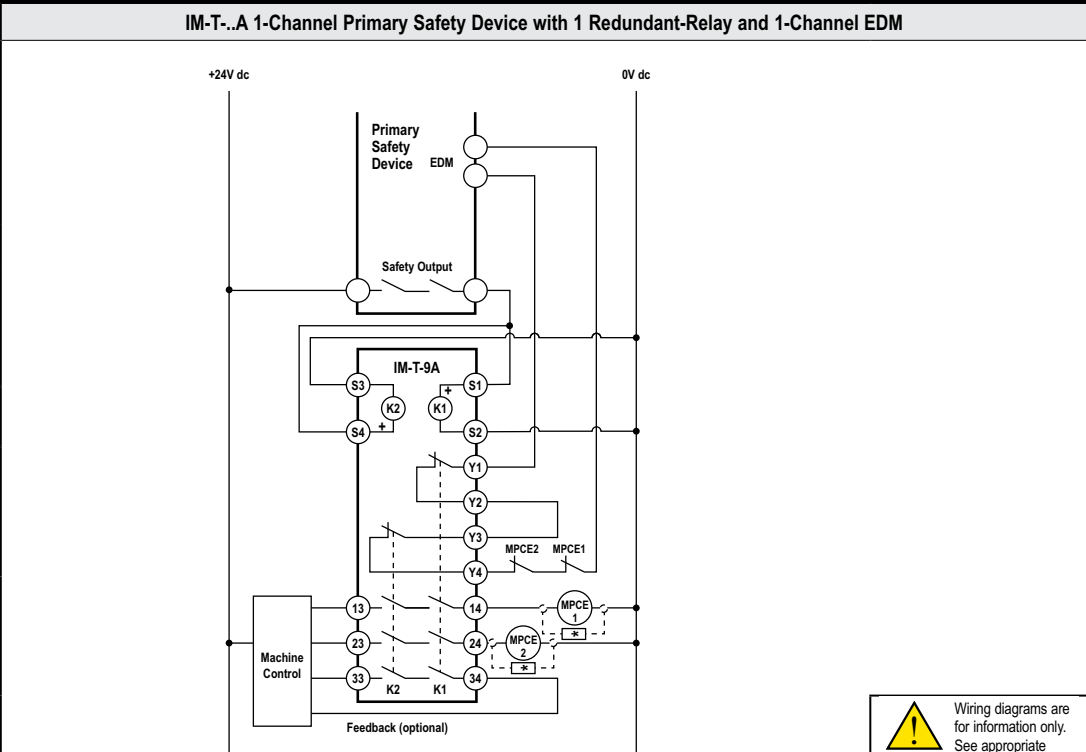
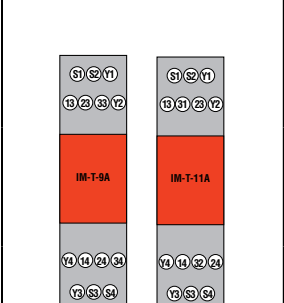

* Arc Suppressors. See manual for specific warnings.

Wiring diagrams are for information only. See appropriate manuals for all specific warnings, cautions and information for use.

More on next page

DUO-TOUCH® SG Two-Hand Control Modules STB Compatible

- Accessories
- Reference
- Hookups
- Wiring Diagrams
- Glossary
- International Reps



Page 552

Models

- AT-FM-10K

AT-FM-10K Terminal Locations



AT-FM-10K to Two STB Touch Buttons with Contact Output

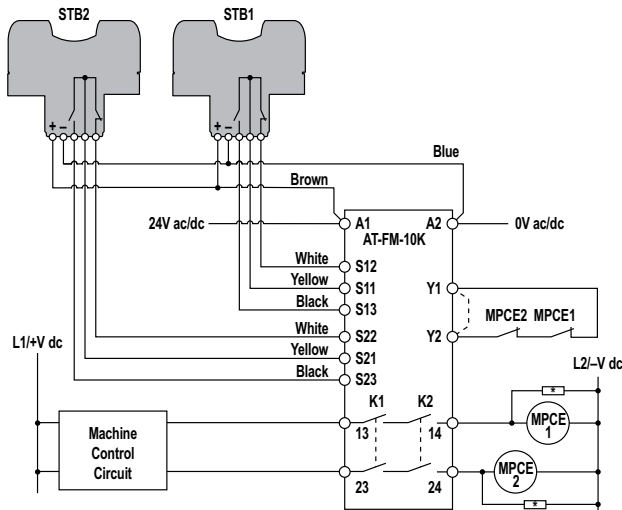

Wiring diagrams are for information only. See appropriate manuals for all specific warnings, cautions and information for use.

AT-FM-10K to Two STB Touch Buttons with PNP (Sourcing) Outputs

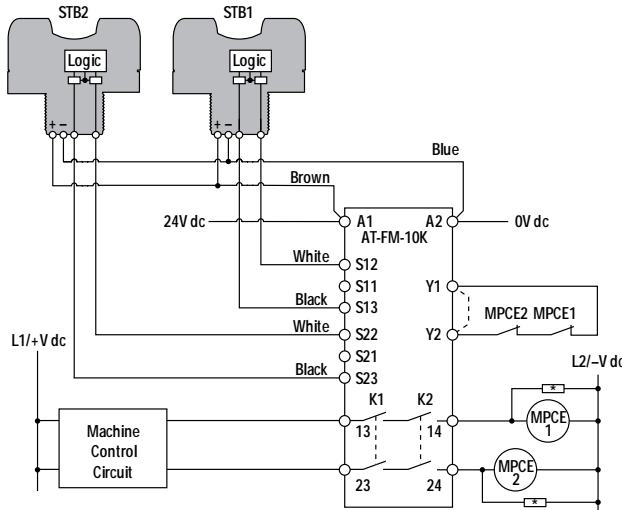

Wiring diagrams are for information only. See appropriate manuals for all specific warnings, cautions and information for use.

AT-FM-10K to Two Mechanical Push Buttons with Contact Outputs

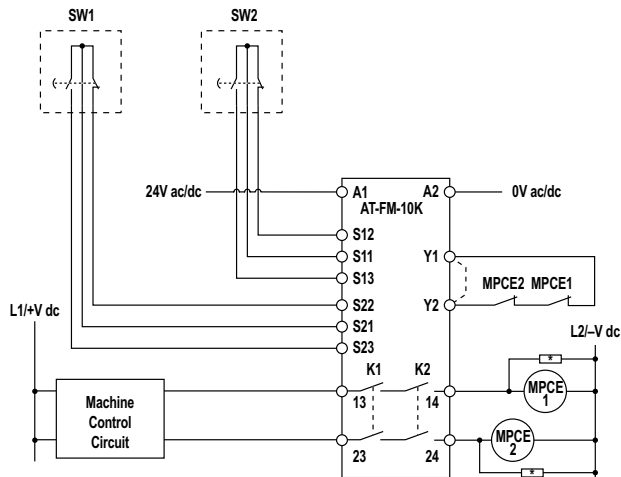

Wiring diagrams are for information only. See appropriate manuals for all specific warnings, cautions and information for use.

More on next page

* Arc Suppressors. See manual for specific warnings.

WD064

DUO-TOUCH® SG Two-Hand Control Modules, STB Compatible

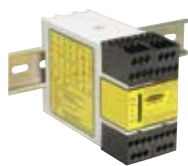

Page 552

Models

- AT-GM-13A
- AT-HM-13A

AT-M-13A Terminal Locations

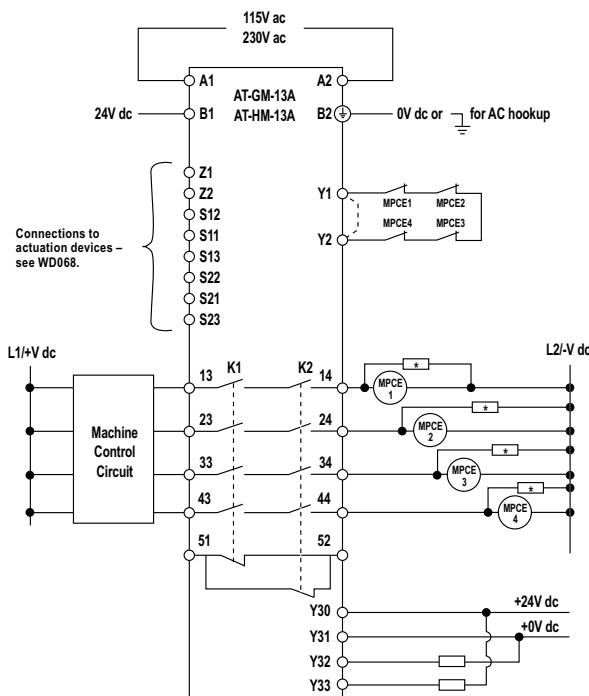
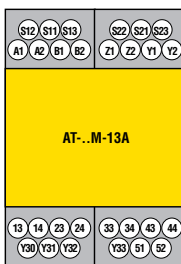

Connections to actuation devices - see WD068.

* Arc Suppressors. See manual for specific warnings.

Wiring diagrams are for information only. See appropriate manuals for all specific warnings, cautions and information for use.

WD065

DUO-TOUCH® SG Two-Hand Control Modules, STB Compatible



Page 552

Models

- AT-GM-11KM
- AT-HM-11KM

AT-M-10K Terminal Locations

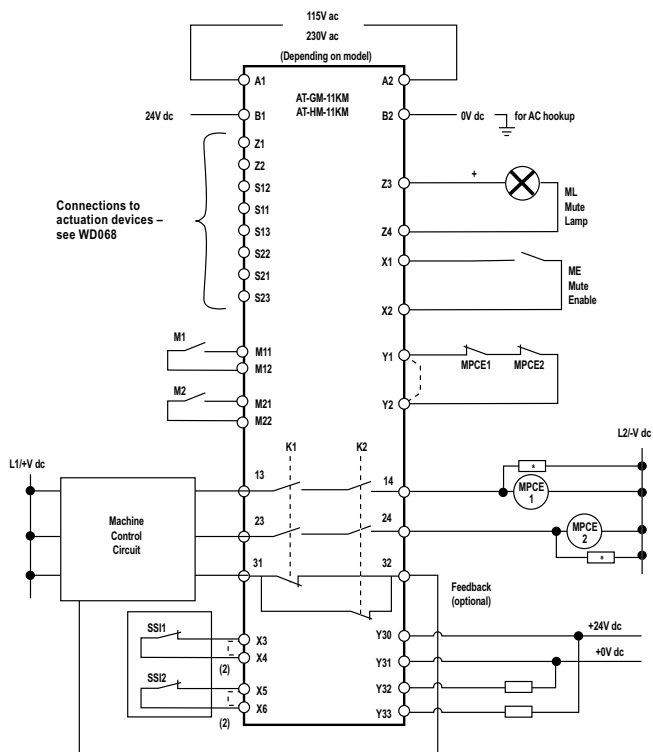
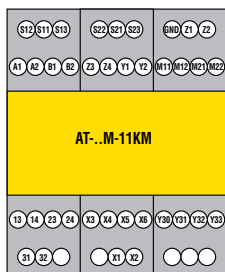

Connections to actuation devices - see WD068

(2) Jumper SSI inputs if not used

* Arc Suppressors. See manual for specific warnings.

Wiring diagrams are for information only. See appropriate manuals for all specific warnings, cautions and information for use.

More on next page